

# Parts Breakdown

Two-Post Lift  
9,000lbs. Capacity

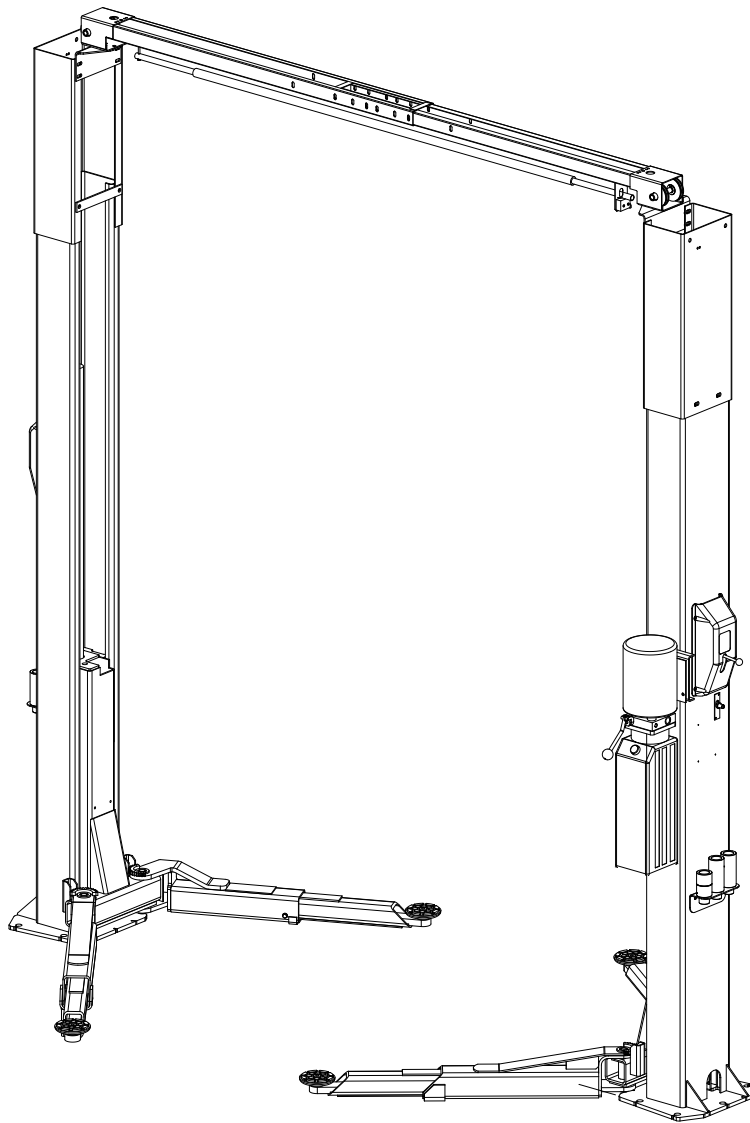

**LP50033**

ITEM	PART #	DESCRIPTION
1	TP9-1000A	R.H. Column Weldment
2	TP9-1100A	L.H. Column Weldment
3	TP9-2000A	Carriage Weldment
4	N480-1	L.H. Overhead
5	N481-1	R.H. Overhead
6	TP10-3006	Top Bracket
7	30400-5005G	Arm Pin
8	30400-5025G	Slider Block Shim (As Required)
9	TP10-6003	Slider Block
10	30400-1025	U SHIM
11	FJ7380	Anchor Bolt
12	N377	Sheave
13	41411	Klipring For 3/4" Shaft
14	N119-1	Sheave Cover
15	40063	1/4"-20NC*3/8"Lg. PHMS Plated
16	30400-5012-1	Press Spring
17	B51-3*26	Spring Pin 3*26Lg.
18	30400-5015	Actuator Pin
19	30400-5017G	GEAR SHIM
20	30400-5014G	PAWL
21	B41-10	FLAT WASHER 10
22	B40-10	SPRING WASHER 10
23	B30-10	HEX NUT M10
24	B84-35	BALL HANDLE
25	40108	1/4"-20NC*1"Lg.HHCS
26	N619	LATCH CABLE BRACKET
27	40641	1/4"-20NC Flanged Lock Nut
28	913303 (40743)	NYLON LOCK NUT 5/8"-11
29	913206 (40970)	FLAT WASHER 16
30	TP9-5001A	EQUALIZER CABLE
31	DL9-9801-3	Overhead Hose
32	FJ7600	LATCH RELEASE CABLE
33	41536	M10-1.5*20Lg. HHCS
34	41655	M10-1.5 Flanged Lock Nut
35	G3T-8005 (N3216)	HOSE CLAMP
36	N618	LATCH CABLE GUIDE
37	41388	WASHER
38	G3T-4001 (FJ7444-8)	SHEAVE SHAFT

39	N3155	Cylinder
40		
41		
42	PL10-9801-2	Mainside Hose
43	FJ6145Y	ADAPTER BRACKET
44	40227	5/16"-18NC*3/8"Lg.PHMS
45	1070922	1.75" EXT.Adapter
46	1070923	3.5" EXT.Adapter
47	B23-4*6	M4*6Lg.PHMS
48	TP6-1002	COVER PLATE
49		POWER UNIT
	P3610	POWER UNIT 1PHASE
	P3046	POWER UNIT 3PHASE
50	PL10-9801-1	HOSE
51	HPRO-Y002	T fitting
52	40854	5/16" External Tooth Lockwasher
53	40271	5/16"-18NC*1-1/2 HHCS
54	40670	5/16"-18NC HEX NUT
55	40286	1/2"-13*1-1/4"HHCS(G.5 )
56	40707	1/2"-13NYLON LOCK NUT
57	H4D-2000-10	1/2" FLAT WASHER
58	TP9-1002	EXTENSION COLUMN
59	TPB10-2002	Column Reinforce
60		Switch Bar Assembly
	N415	1 Phase Switch Bar Assembly
	N434	3 Phase Switch Bar Assembly
61	B41-6 (40795)	FLAT WASHER 1/4"
62	G3T- 4003(FJ7871)	LIMITED BAR SPACER
63	40114	1/4"-20NC*2-3/4"Lg.HHCS
64	911403	1/4"-20NC Nylon Lock Nut
65		OVERHEAD SWITCH
	N413	OVERHEAD SWITCH 1 Phase
	N432	OVERHEAD SWITCH 3 Phase
66	40099	1/4"-20NC*3/4"Lg.HHCS
67	FA7366	3 Phase Switch Box
68	40275	M5-10mm PHMS Plated
69	FJ7352-3	Straight Fitting
70	TP6-5005-1	Cover Plate

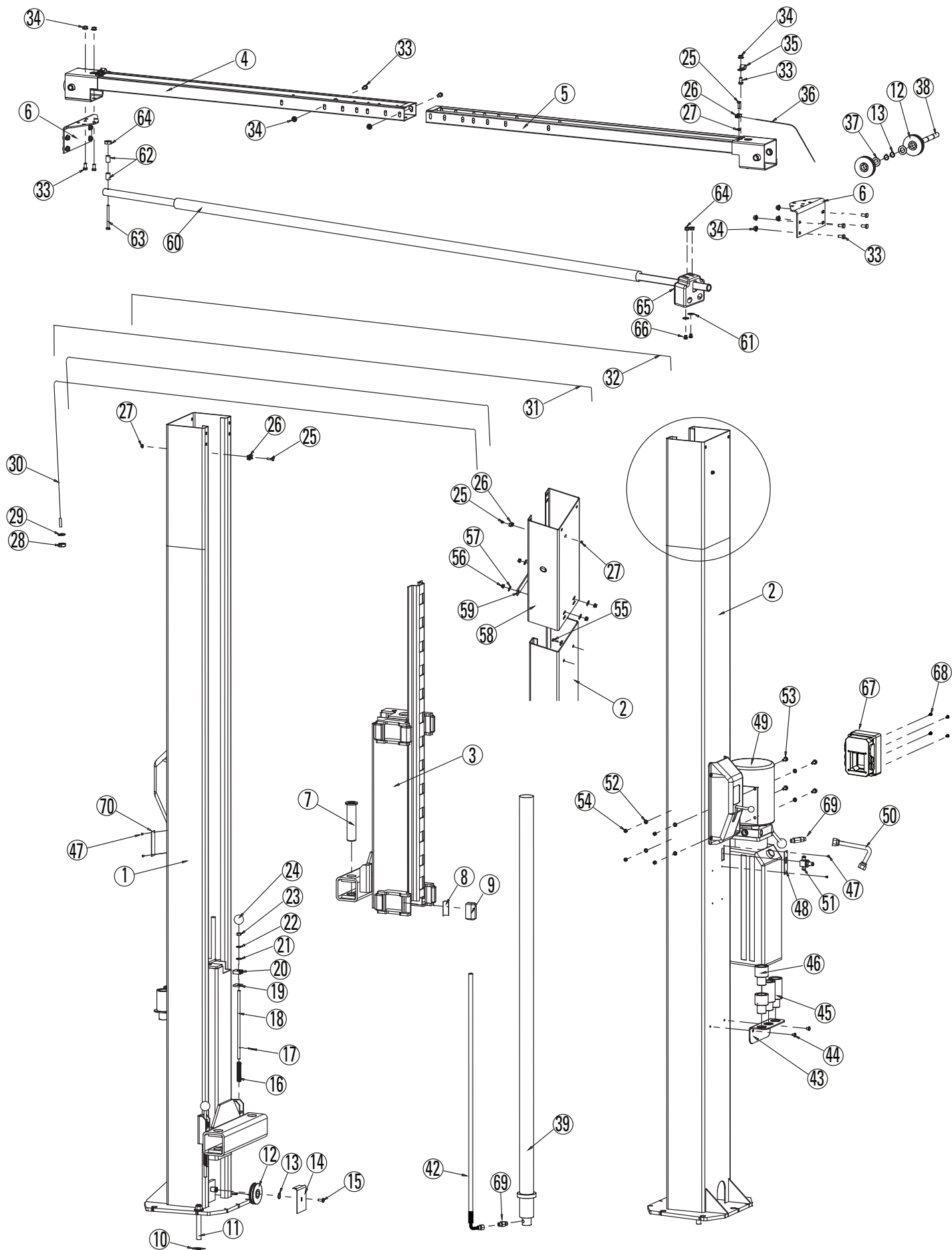

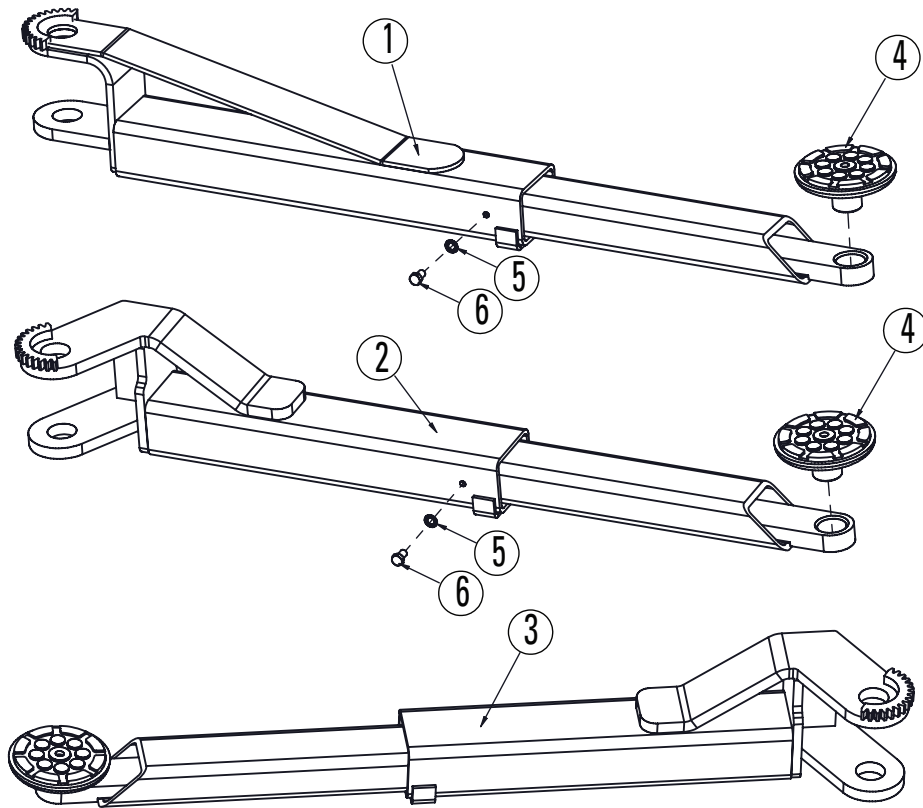

ITEM	PART #	DESCRIPTION
1	TP9-3000	ARM ASSEMBLY
2	TP9-4000A	LEFT FRONT ARM ASSEMBLY
3	TP9-4000B	RIGHT FRONT ARM ASSEMBLY
4	30400-6005-1	ADAPTER ASSEMBLY
5	40843	3/8" INTERNAL TOOTH WASHER
6	40155	3/8"-16NC*5/8"Lg. HHCS GRADE 8

# Locking Latch Detail (Right Column)

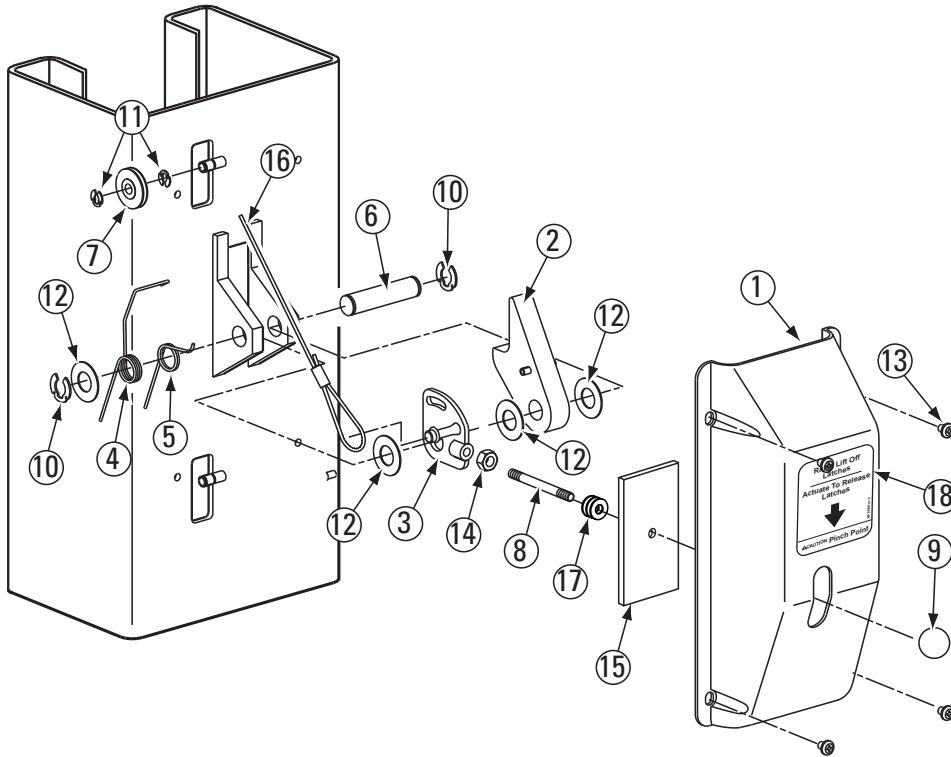

ITEM	PART#	DESCRIPTION
1	TP6-5003	Control Side Cover
2	TP10-1010	Locking Latch Dog
3	FJ7594-2	Control Plate
4	FJ7566-10	Spring
5	FJ7382-9	Spring
6	FJ7382-34	Latch Shaft
7	FJ7322	Locking Latch Sheave
8	FJ7382-18	Handle
9	FC134-91	Ball Handle
10	41411	Truarc Klipring #5304-75 for 3/4" Shaft
11	41410	Truarc Klipring #5304-37 for 3/8" Shaft
12	41388	1-1/2" O.D. x 3/4" I.D. x .045" Mach. Bush.
13	40227	5/16"-18NC x 3/8" Lg. PHMS
14	40658	3/8" - 16NC Hex Jam Nut
15	N617	Slot Cover
16	FJ7600	Locking Latch Cable
17	40820	3/8" Flat Washer
18	NP266	Latch Release Decal

## Locking Latch Detail (Left Column)

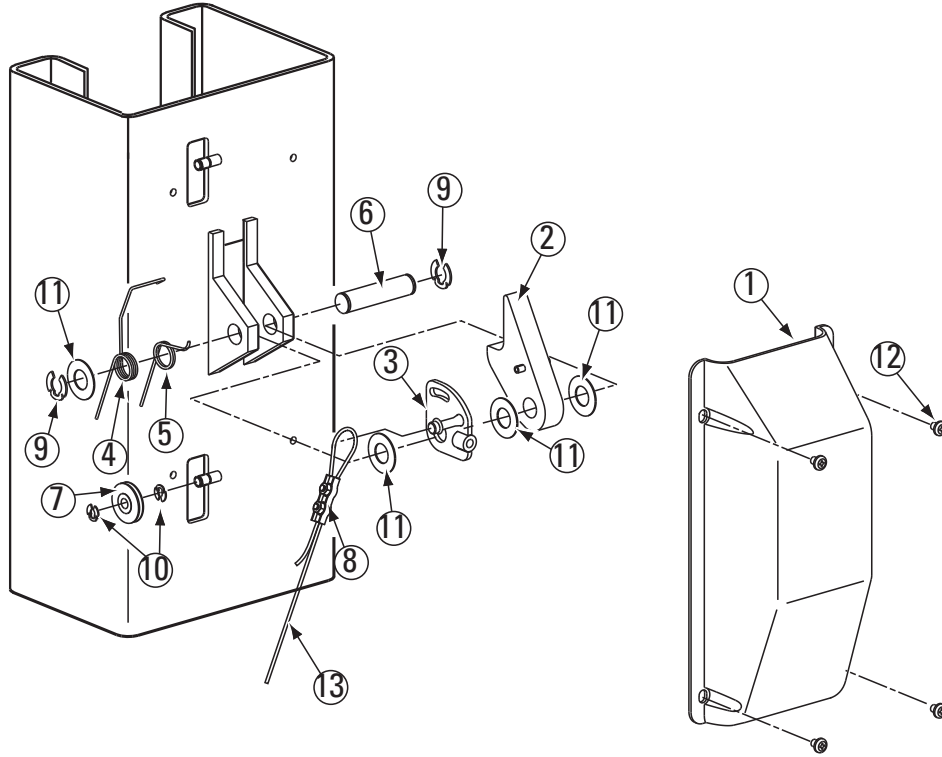

ITEM	PART#	DESCRIPTION
1	TP6-5004	Latch Cover
2	TP10-1010	Locking Latch Dog
3	FJ7594-2	Control Plate
4	FJ7566-10	Spring
5	FJ7382-9	Spring
6	FJ7382-34	Latch Shaft
7	FJ7322	Locking Latch Sheave
8	N63-1	Latch Cable Clamp
9	41411	Truarc Klipring #5304-75 for 3/4" Shaft
10	41410	Truarc Klipring #5304-37 for 3/8" Shaft
11	41388	1-1/2" O.D. x 3/4" I.D. x .045" Mach. Bush.
12	40227	5/16"-18NC x 3/8" Lg. PHMS
13	FJ7600	Locking Latch Cable

## NOTES

**Vehicle Service Group<sup>SM</sup>**  
2700 Lanier Drive  
Madison, IN 47250, USA  
1-800-640-5438  
[www.vsgdover.com](http://www.vsgdover.com)



© **Vehicle Service Group<sup>SM</sup>**  
All Rights Reserved. Unless otherwise  
indicated, **Vehicle Service Group<sup>SM</sup>**  
and all other trademarks are property  
of Dover Corporation and its affiliates.