

ITEM	PART.No	DESCRIPTION.	QT.Y
1	TB-M-0940000	MOTORCYCLE CLAMPING ASSEMBLY FIXTURE	1
2	TB-M-0950000	BALANCING SHAFT	1
3	GB70.1-M6×20	INNER HEXA CYLINDRICAL SCREW	2
4	TB-M-0130000	TO EXTEND THE FOOT ASSEMBLY	1
5	GB70.1-M8×25	INNER HEXA CYLINDRICAL SCREW	2

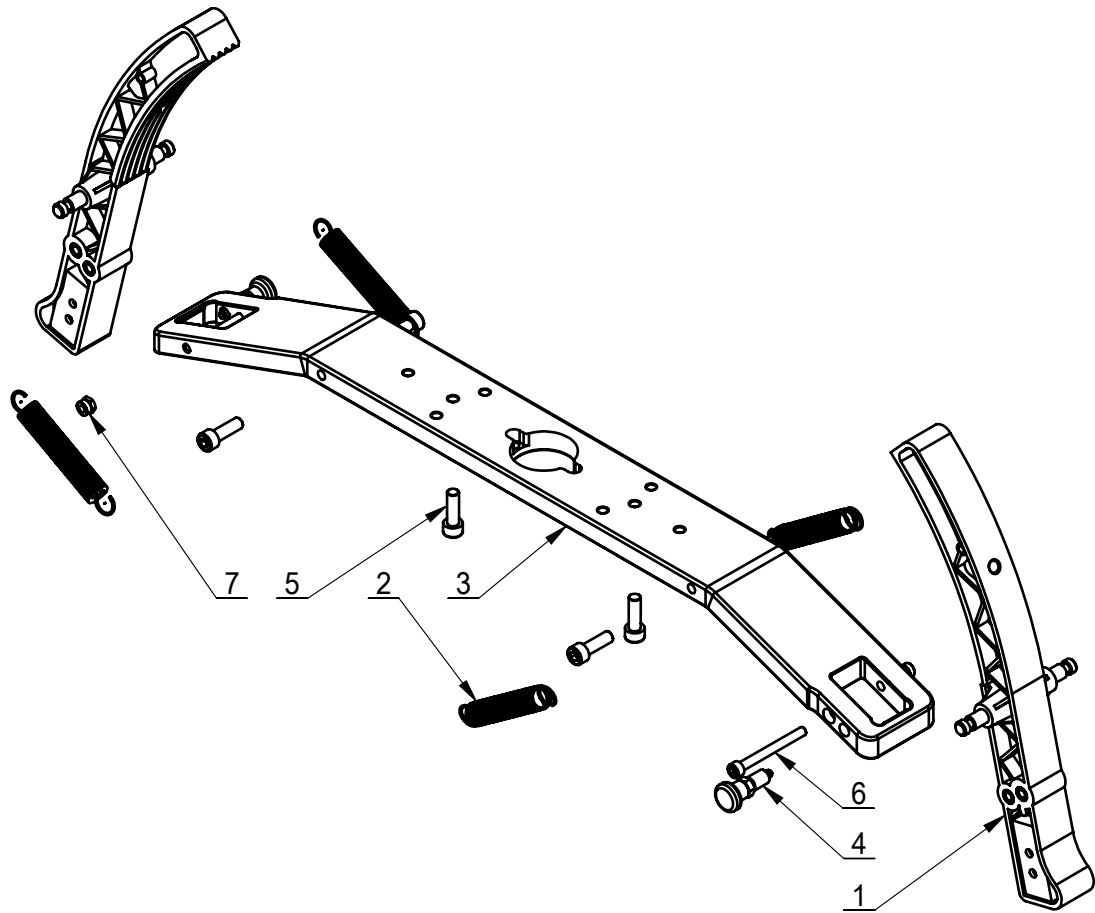

ITEM	PART.No	DESCRIPTION.	QT.Y
1	TB-M-0121000	HAND ASSEMBLY FIXTURE	2
2	TB-M-0120002	SPRING	4
3	TB-M-0940002	SUPPORT BRACKET	1
4	TB-M-0122000	LIMIT SWITCH	2
5	GB70.1-M8×25	INNER HEXA CYLINDRICAL SCREW	6
6	GB70.1-M6×70	INNER HEXA CYLINDRICAL SCREW	2
7	GB889.1-M6	1-TYPE PREVAILING TORQUE TYPE HEXAGON LOCK NUT	2

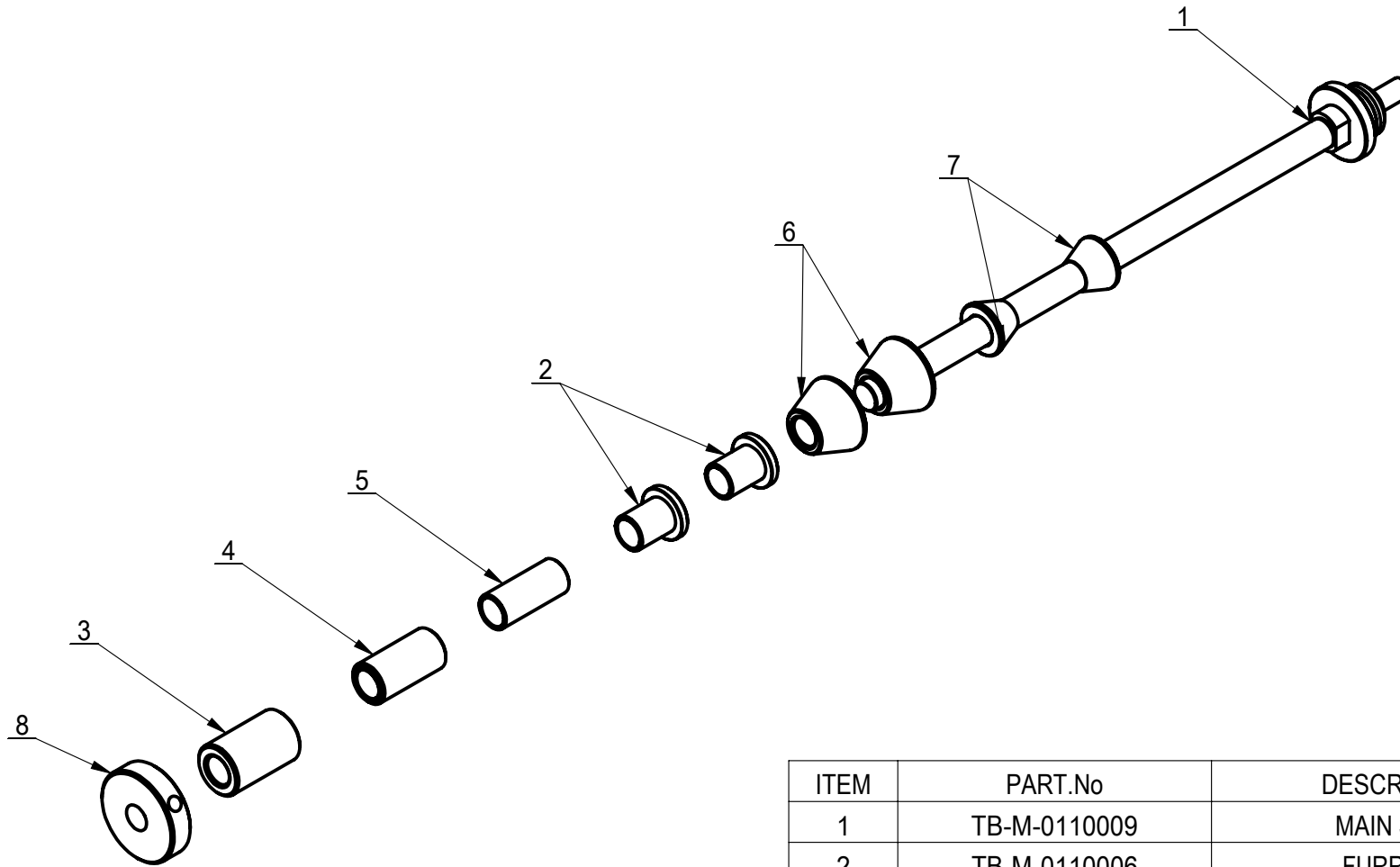

ITEM	PART.No	DESCRIPTION.	QT.Y
1	TB-M-0110009	MAIN SHAFT	1
2	TB-M-0110006	FURREUL 4	2
3	TB-M-0110003	FURREUL 1	1
4	TB-M-0110004	FURREUL 2	1
5	TB-M-0110005	FURREUL 3	1
6	TB-M-0110001	CONE(LARGE)	2
7	TB-M-0110002	CONE(SMALL)	2
8	TB-M-0110008	LOCK NUT	1

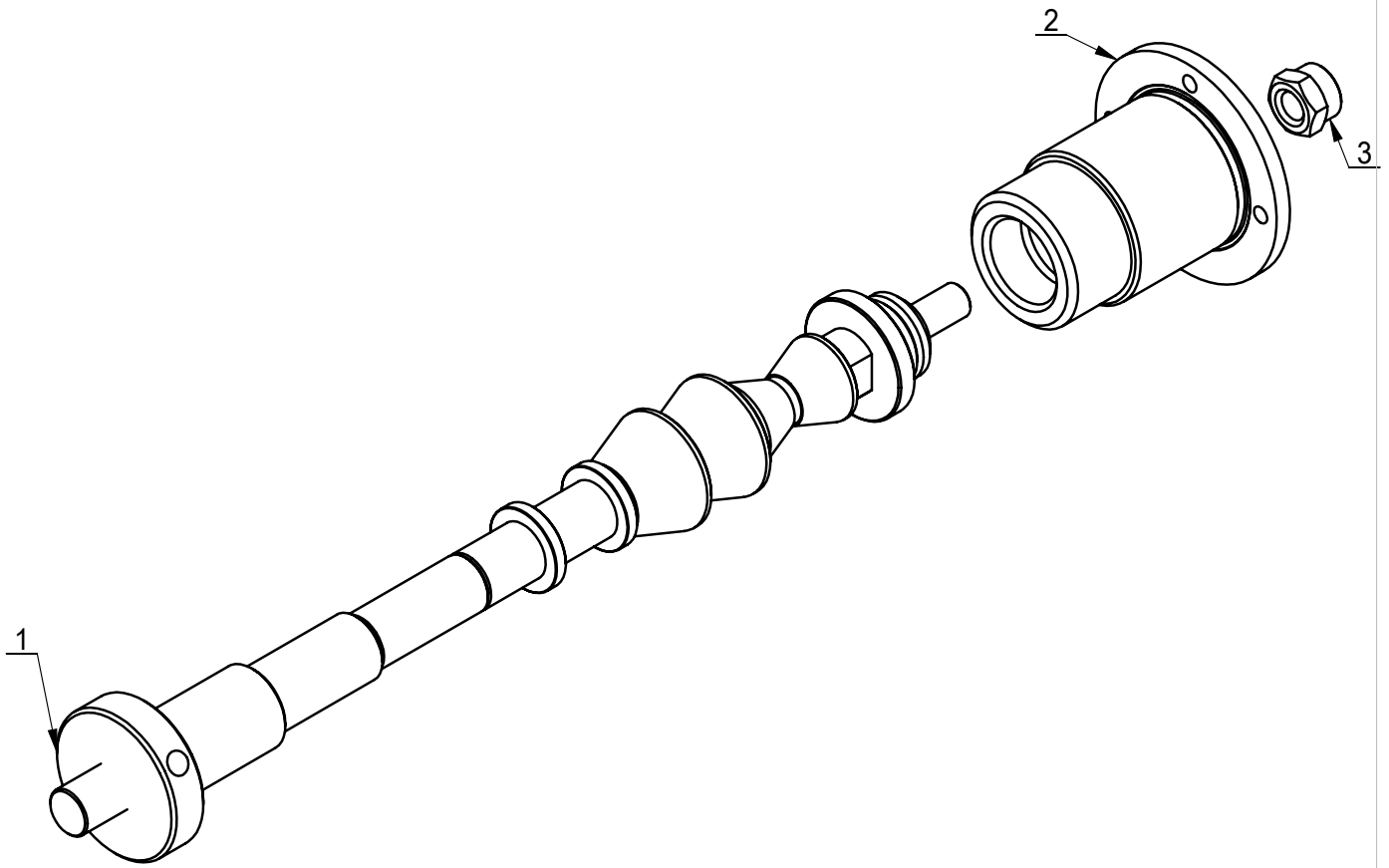

ITEM	PART.No	DESCRIPTION.	QT.Y
1	TB-M-0110000	BALANCE SHAFT ASSEMBLY COMPONENTS	1
2	TB-M-0950001	FIXED SLEEVE	1
3	GB889.1-M10	1-TYPE PREVAILING TORQUE TYPE HEXAGON LOCK NUT	1